

"ST-3" 8" Bar - (C) For Extension

Release 01 (06/05)

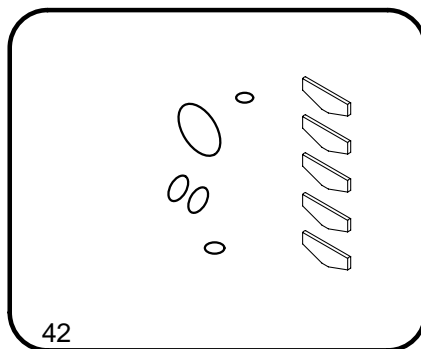
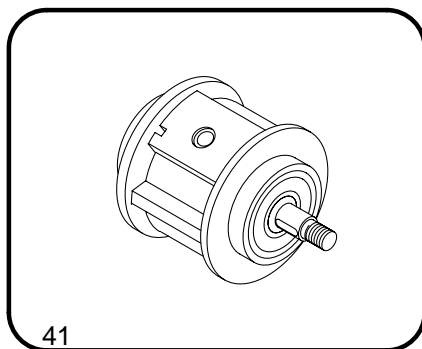
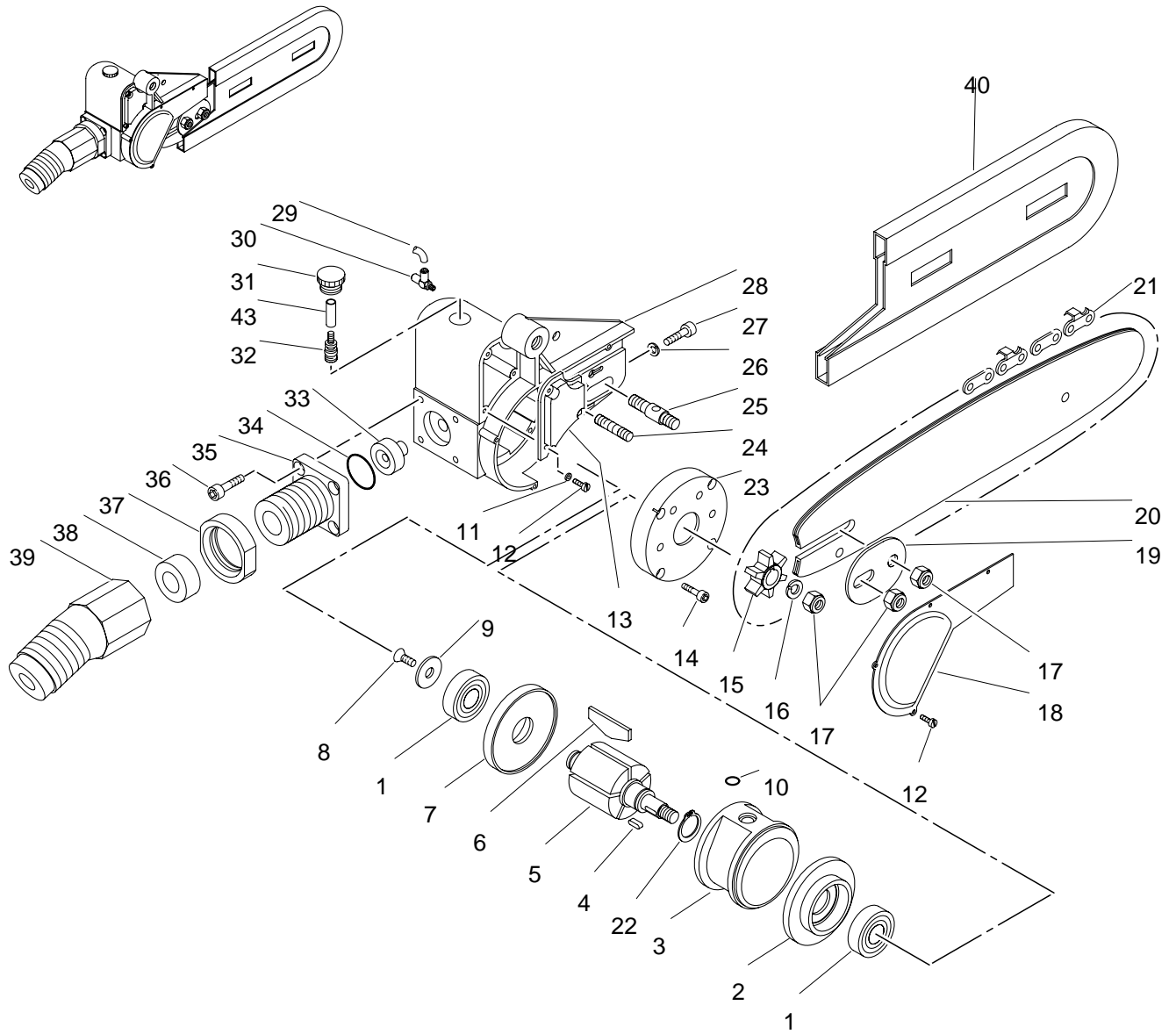

ST-3 Chain Saw 8" x 1/4"

<u>Ref</u>	<u>Qty</u>	<u>Code</u>	<u>Description</u>
1	2	0127.0133	bearing
2	1	0122.0140	forward flange
3	1	0188.0104	rotor housing
4	1	0130.0103	shaft key
5	1	0187.0108	rotor
6	5	0186.0106	air vanes
7	1	0122.0139	rear flange
8	1	0106.0358	screw
9	1	0101.0112	washer
10	1	0123.0127	o-ring
11	3	0101.0150	washer
12	7	0106.0226	screw
13	1	0183.0112	oiler cover plate
14	4	0106.0170	bolt
15	1	0189.0101	sprocket
16	1	0101.0127	lock washer
17	3	0100.0126	nut
18	1	0132.0117	cover plate
19	1	0101.0162	washer
20	1	0153.0113	bar 8" x 1/4"
21	1	PACK.0410	chain - 8"
22	1	0126.0138	snap ring
23	1	0183.0101	flange plate
24	1	0106.0154	stud bolt
25	1	0106.0153	stud bolt
26	1	0101.0125	washer
27	1	0106.0149	adjustment bolt
28	1	0171.0170	motor casing
29	4cm	0120.0401	tubing 4 x 2
30	1	0112.0162	oil regulator
31	1	0133.0161	oil cap
32	1	0125.0160	oiler air inlet
33	1	0128.0113	handle guide
34	1	0123.0129	o-ring
35	1	0166.0125	extension adapter
36	4	0106.0203	bolt
37	1	0161.0114	locking collar
38	1	0142.0112	grommet-angle adapter
39	1	0166.0117	angle adapter
40	1	0132.0178	bar protector 8"
41	1	6146.0005	motor complete
42		PACK.0406	o-ring/air vane kit
43	2cm	0120.0112	air inlet tube