

# "STAR 30"

Release 02 (06/05)

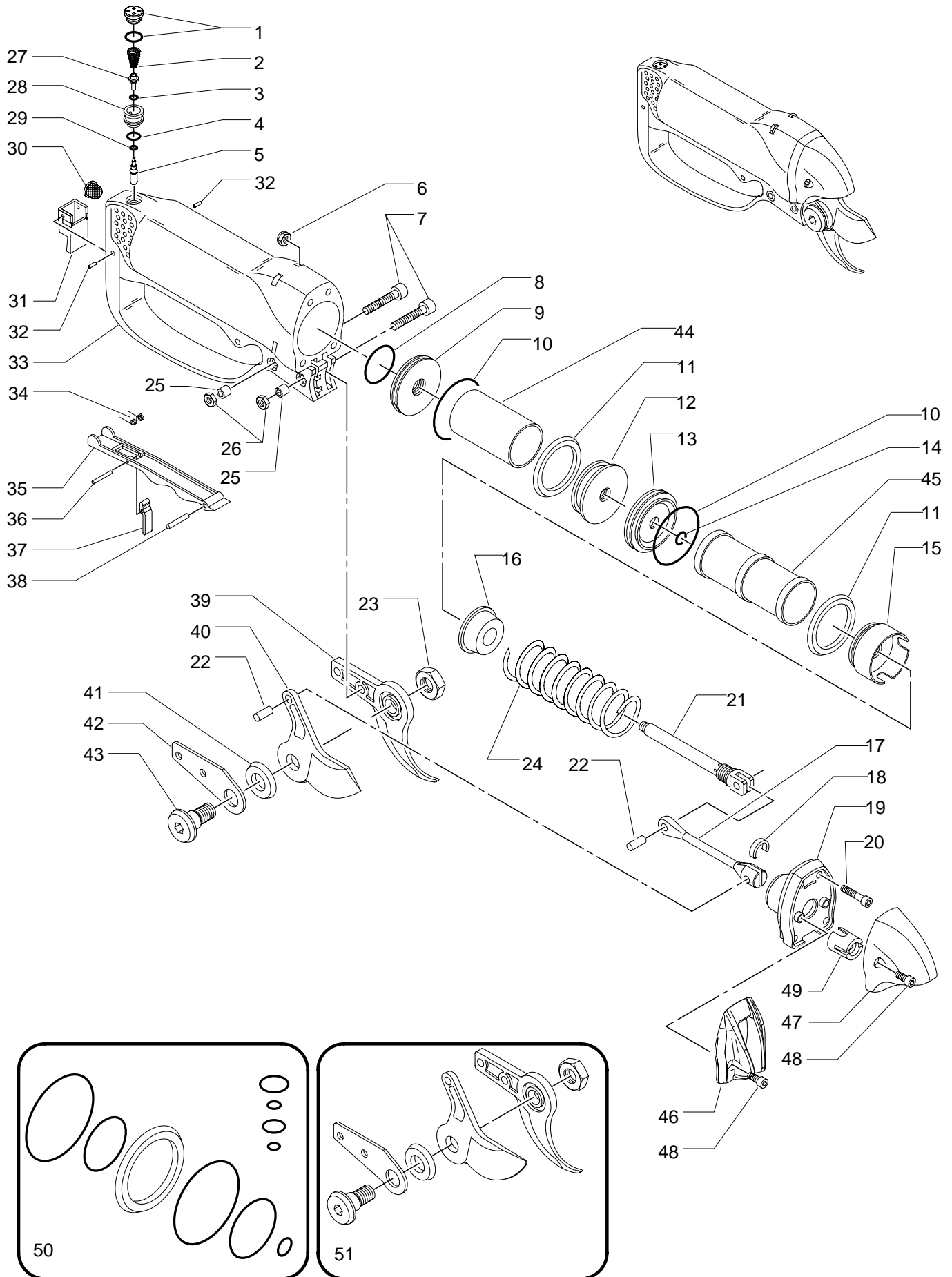

# Star 30 F

<u>Ref</u>	<u>Qty</u>	<u>Code</u>	<u>Description</u>
1	1	6133.0005	valve cap & seal
2	1	0164.0143	valve spring
3	1	0123.0104	o-ring
4	1	0123.0228	o-ring
5	1	6129.0003	valve w/o-ring
6	4	0100.0105	self locking nut
7	2	0106.0146	allen bolt
8	1	0123.0147	o-ring
9	1	0184.0106	rear plate
10	2	0123.0117	o-ring
11	2	0123.0261	piston ring
12	1	0169.0140	rear piston
13	1	0184.0105	divide plate
14	1	0123.0210	o-ring
15	1	0169.0141	front piston
16	1	0173.0111	rubber stopper
17	1	0170.0112	connecting rod
18	1	0164.0161	rivet cap
19	1	0183.0123	piston cover
20	4	0106.0152	bolt
21	1	0129.0164	piston rod
22	2	0159.0132	blade rivet
23	1	0100.0112	blade nut
24	1	0164.0160	piston spring
25	2	0134.0160	spacer
26	2	0100.0101	self locking nut
27	1	6125.0003	valve w/o-ring
28	1	0134.0155	valve spacer
29	1	0123.0115	o-ring
30	1	0102.0108	air filter
31	1	0167.0104	air director
32	2	0159.0137	roll pin
33	1	0171.0244	cylinder body
34	1	0164.0163	safety spring
35	1	6148.0003	trigger assembly
36	1	0159.0136	roll pin
37	1	0168.0111	safety catch
38	1	0125.0146	pin
39	1	0175.0143	anvil
40	1	0175.0142	blade
41	1	0101.0116	blade spacer
42	1	0174.0107	blade support
43	1	0125.0191	blade bolt
44	1	0172.0107	rear cylinder sleeve
45	1	0172.0108	front cylinder sleeve
46	1	0132.0250	upper piston cover
47	1	0132.0235	rod protector
48	2	0106.0334	bolt
49	1	0142.0122	rubber guide
50		PACK.1410	o-ring kit
51		6175.0001	blade/anvil assembly