

"STAR 35"

Release 05 (06/05)

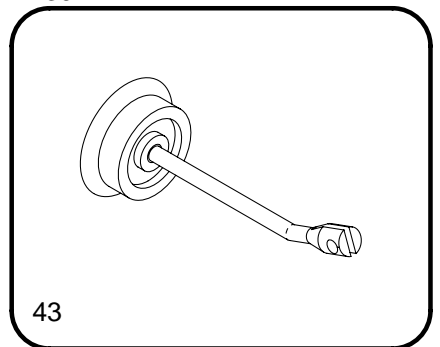
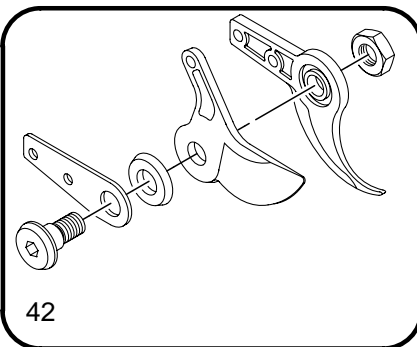
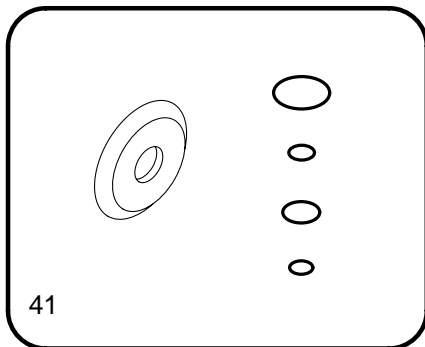
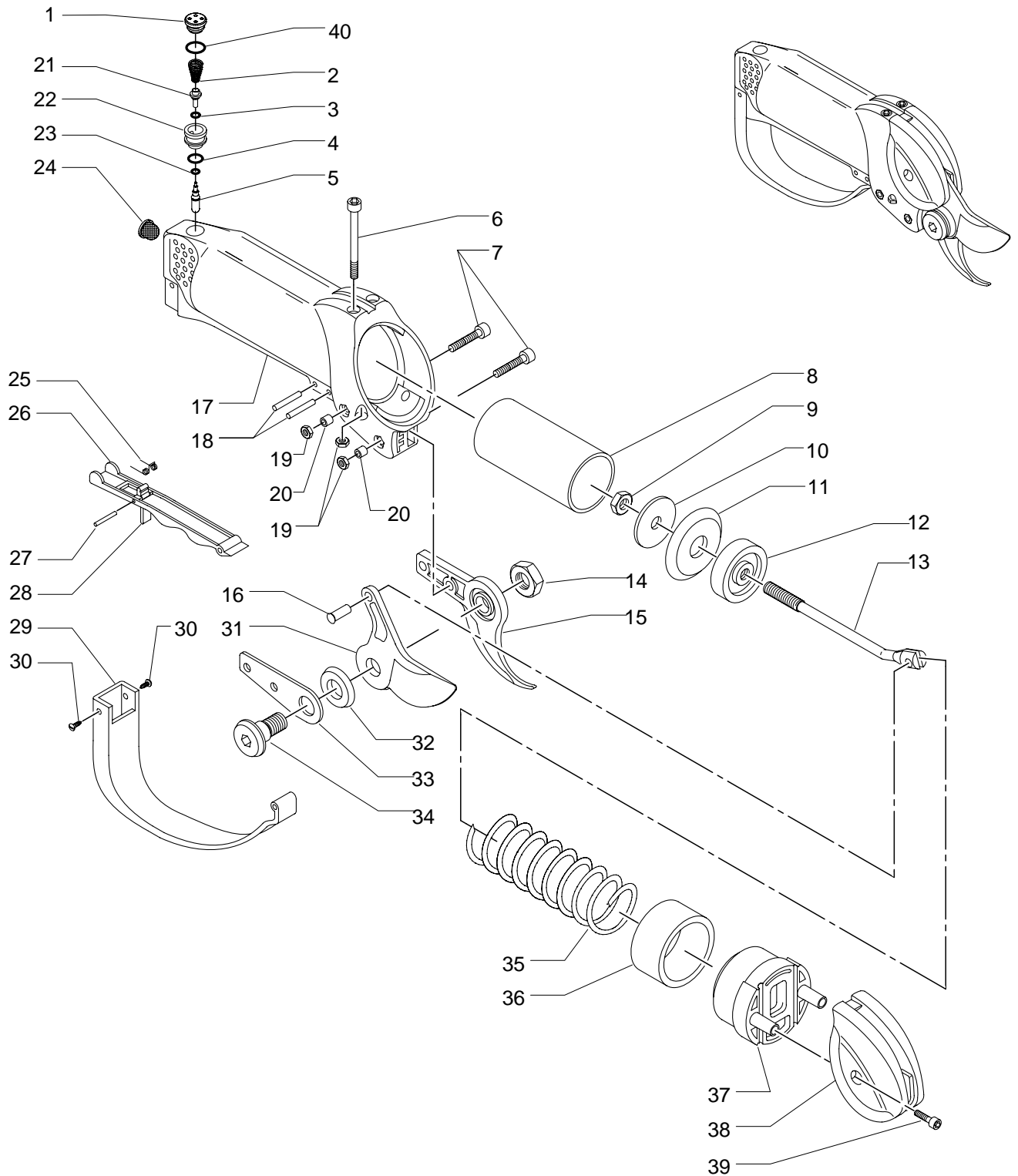

Star 35

<u>Ref</u>	<u>Qty</u>	<u>Code</u>	<u>Description</u>
1	1	6133.0005	valve cap & seal
2	1	0164.0143	valve spring
3	1	0123.0104	o-ring
4	1	0123.0228	o-ring
5	1	6129.0003	valve w/o-ring
6	2	0106.0332	bolt
7	2	0106.0146	allen bolt
8	1	0172.0109	cylinder sleeve
9	1	0100.0118	nut
10	1	0101.0217	piston washer
11	1	0123.0234	piston ring
12	1	0169.0147	piston
13	1	0170.0114	connecting rod
14	1	0100.0112	blade nut
15	1	0175.0146	blade
16	1	0177.0106	blade rivet
17	1	0171.0246	cylinder body
18	2	0125.0146	pin
19	4	0100.0122	self locking nut
20	2	0134.0155	spacer
21	1	6125.0003	valve w/o-ring
22	1	0134.0155	valve spacer
23	1	0123.0115	o-ring
24	1	0102.0108	air filter
25	1	0164.0163	safety spring
26	1	6148.0003	trigger assembly
27	1	0159.0136	roll pin
28	1	0168.0111	safety catch
29	1	0132.0244	handle guard
30	2	0106.0357	self-threading screw
31	1	0175.0156	blade
32	1	0101.0116	blade spacer
33	1	0174.0108	blade support
34	1	0125.0191	blade bolt
35	1	0164.0162	piston spring
36	1	0173.0115	piston cushion
37	1	0183.0125	piston cover
38	1	0132.0246	rod protector
39	2	0106.0334	bolt
40	1	0123.0153	o-ring
41		PACK.1400	o-ring kit
42		6175.0003	blade/anvil assembly
43		6169.0009	piston/connecting rod assembly