

# "SUPER STAR 2"

Release 03 (01/06)

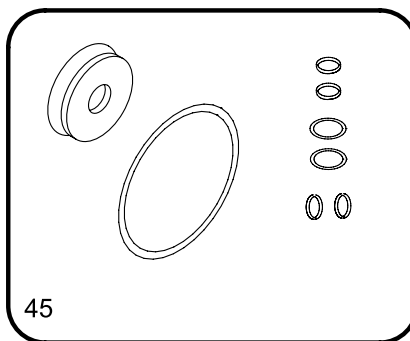
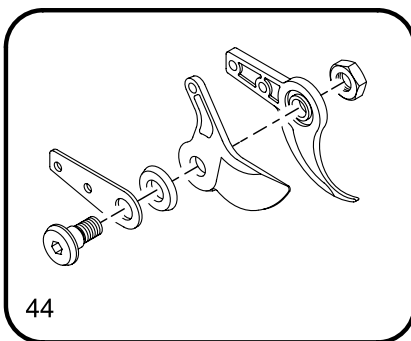
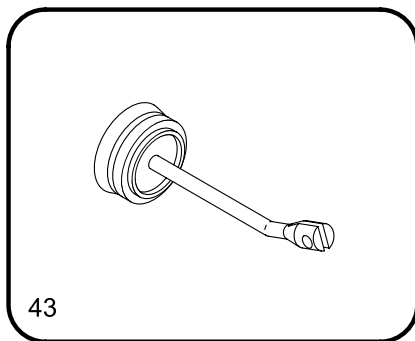
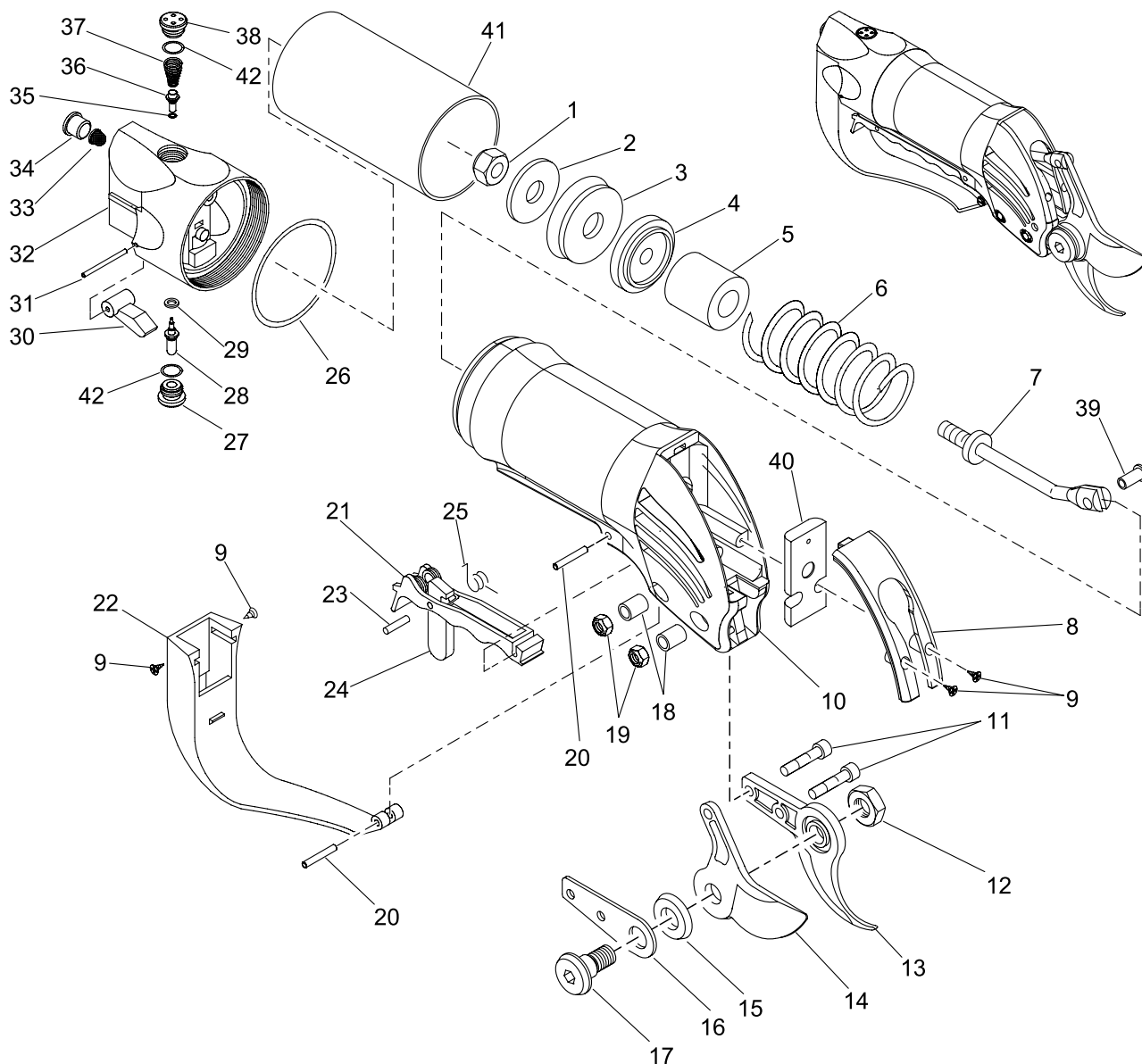

# Super Star 2 P5

<u>Ref</u>	<u>Qty</u>	<u>Code</u>	<u>Description</u>
1	2	0100.0118	nut
2	1	0101.0216	piston washer
3	1	0123.0235	piston rim seal
4	1	0169.0148	piston
5	1	0173.0107	bumper
6	1	0164.0142	piston spring
7	1	0170.0114	connecting rod
8	1	0183.0130	front cover
9	4	0106.0357	self threading screw
10	1	0171.0257	cylinder body
11	2	0106.0146	allen bolt
12	1	0100.0112	blade nut
13	1	0175.0146	anvil
14	1	0175.0156	blade
15	1	0101.0116	blade spacer
16	1	0174.0108	blade support
17	1	0125.0191	blade bolt
18	2	0134.0159	spacer
19	2	0100.0122	self locking nut
20	2	0125.0146	pin
21	1	6148.0004	trigger assembly
22	1	0132.0265	hand guard
23	1	0159.0103	roll pin
24	1	0168.0107	safety
25	1	0164.0141	safety spring
26	1	0123.0193	O-ring
27	1	0133.0111	lower end cap w/o-ring
28	1	0129.0130	valve pin & seal
29	1	0123.0115	O-ring
30	1	0148.0118	short valve lever
31	1	0125.0147	pin
32	1	0171.0273	valve body
33	1	0102.0108	air filter
34	1	0133.0109	end cap
35	1	0123.0104	o-ring
36	1	6125.0003	valve w/o-ring
37	1	0164.0143	valve spring
38	1	6133.0005	valve cap & seal
39	1	0177.0106	rivet
40	1	0142.0121	front dust seal
41	1	0172.0100	cylinder sleeve
42	2	0123.0153	o-ring
43	1	6169.0010	piston/connecting rod kit
44	1	6175.0003	blade/anvil assembly
45		PACK.1600	o-ring kit